



مرکز تخصصی مشاوره، فروش  
و خدمات باتری‌های صنعتی

خیابان ولیعصر، پایین تر  
از پارک ساعی، پلاک ۲۳۱  
شرکت حامی انرژی مانا



۰۹۲۰۸۴۸۰۴۴۸



۰۲۱-۸۸۴۸۰۴۴۹



manabattery.ir



**با تخصص، روشن بمان!**



**SABA BATTERY**

HAJAMINI INDUSTRIAL GROUP

# 12 SB 18 (12V 18Ah)



## Outer Dimensions (mm)

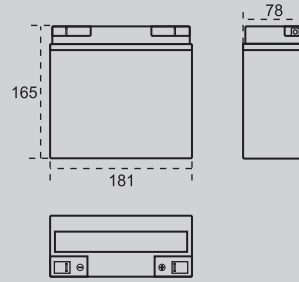

## Specifications

Nominal Voltage		12 V
Rated Capacity ( 10 Hour Rate )		18 Ah
Dimensions	Total Height	165 mm
	Height	165 mm
	Length	181 mm
	Width	78 mm
Terminal		F1 / F2
Container Material		ABS (UL94-HB/V0)
Weight Approx (±2.5%)		5.8 Kg

## Terminal Type brass core (mm) ( F1 )

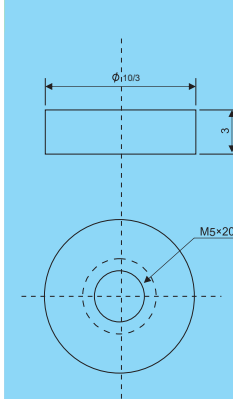

## Terminal Type bolt and nut (mm) ( F2 )

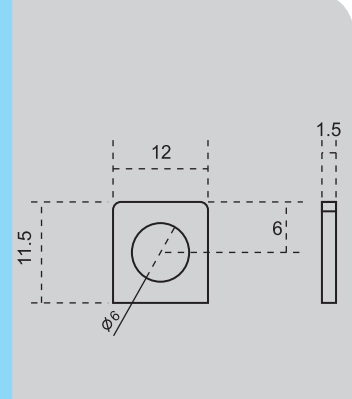

## Characteristics

Capacity 25°C (77°F)	10 hour-rate	18 Ah
	3 hour-rate	12.9 Ah
	1 hour-rate	9.4 Ah
Internal Resistance	Full Charge Battery at 25°C (77°F)	15 mΩ
Capacity Affected by Temperature (10 Hour Rate)	35°C	18.3 Ah
	25°C	18 Ah
	0°C	15.4 Ah
	-10°C	12.8 Ah
Self-Discharge at 25°C (77°F)	Capacity After The 3 Month of Storage	91 %
	Capacity After The 6 Month of Storage	82 %
	Capacity After The 12 Month of Storage	64 %
Charge Constant Voltage	Cycle	Voltage 2.40-2.45 / Cell
	Float	Voltage 2.23-2.28 / Cell

## Discharge Curves 25°C (77°F)

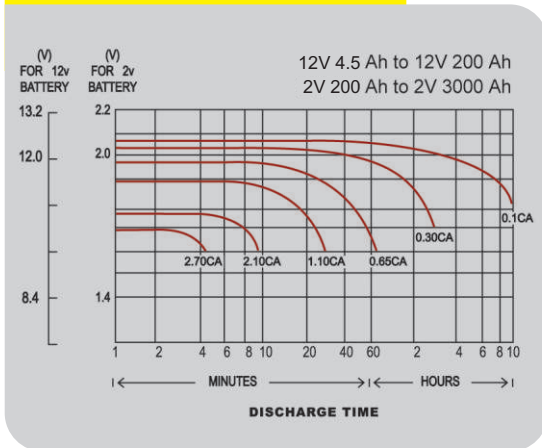

## Discharge and Final Voltage Table According to IEC60896-21 Standard

Discharge time	0.25 h	1 h	3 h	5 h	8 h	10 h
Final voltage	1.60 VPC	1.60 VPC	1.70 VPC	1.73 VPC	1.75 VPC	1.80 VPC

## Constant Current (A) Discharge Table at 25°C (77°F)

Amount of Current (A)	Discharge Time						
	1 h	2 h	3 h	5 h	8 h	10 h	20 h
	9.4	6	4.3	2	1.9	1.8	0.95