



مرکز تخصصی مشاوره، فروش
و خدمات باتری‌های صنعتی

خیابان ولیعصر، پایین تر
از پارک ساعی، پلاک ۲۱۳۱
شرکت حامی انرژی مانا

۰۹۲۰۸۴۸۰۴۴۸



۰۲۱-۸۸۴۸۰۴۴۹



manabattery.ir



با تخصص، روشن بمان!



SABA BATTERY

HAJAMINI INDUSTRIAL GROUP

12 SB 120 (12V 120Ah)



Outer Dimensions (mm)

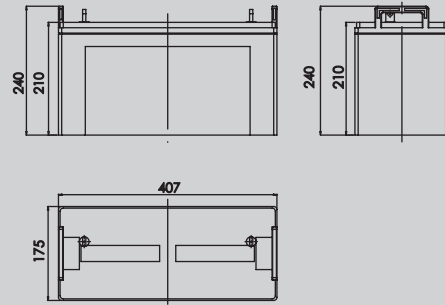

Specifications

Nominal Voltage		12 V
Rated Capacity (10 Hour Rate)		120 Ah
Dimensions	Total Height	233 mm
	Height	209 mm
	Length	407 mm
	Width	175 mm
Terminal		F1
Container Material		ABS (UL94-HB/V0)
Weight Approx (±2.5%)		36 Kg

Terminal Type (mm)

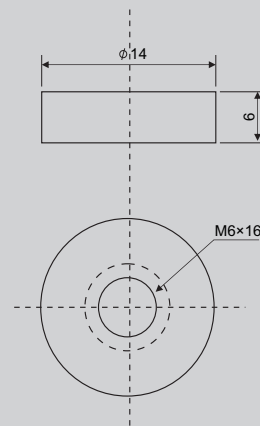

Characteristics

Capacity 25°C (77°F)	10 hour-rate 3 hour-rate 1 hour-rate	120 Ah 90 Ah 66 Ah
Internal Resistance	Full Charge Battery at 25°C (77°F)	4 mΩ
Capacity Affected by Temperature (10 Hour Rate)	35°C 25°C 0°C -10°C	122.4 Ah 120 Ah 102 Ah 90 Ah
Self-Discharge at 25°C (77°F)	Capacity After The 3 Month of Storage Capacity After The 6 Month of Storage Capacity After The 12 Month of Storage	91 % 82 % 64 %
Charge Constant Voltage	Cycle	Voltage 2.40-2.45 / Cell
	Float	Voltage 2.23-2.28 / Cell

Discharge Curves 25°C (77°F)

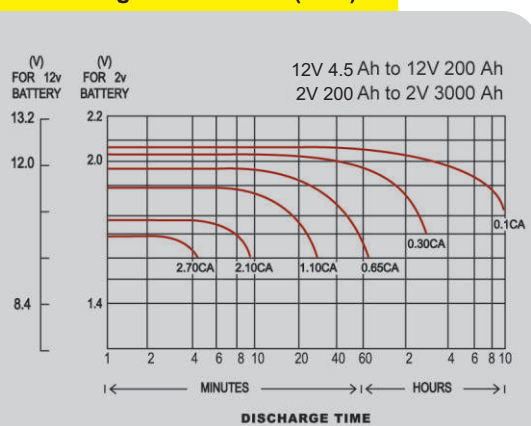

Discharge and Final Voltage Table According to IEC60896-21 Standard

Discharge time	0.25 h	1 h	3 h	5 h	8 h	10 h
Final voltage	1.60 VPC	1.60 VPC	1.70 VPC	1.73 VPC	1.75 VPC	1.80 VPC

Constant Current (A) Discharge Table at 25°C (77°F)

Amount of Current (A)	Discharge Time						
	1 h	2 h	3 h	5 h	8 h	10 h	20 h
	66	38.16	30	19.2	13.2	12	6.48